

Crescendo at Cadence
DELANEY

Approx. square feet: 2,200
Stories: 1
Bedrooms: 3 - 4

Garage: 2-car
Plan Number: L22D

Floor Plan
Main Floor

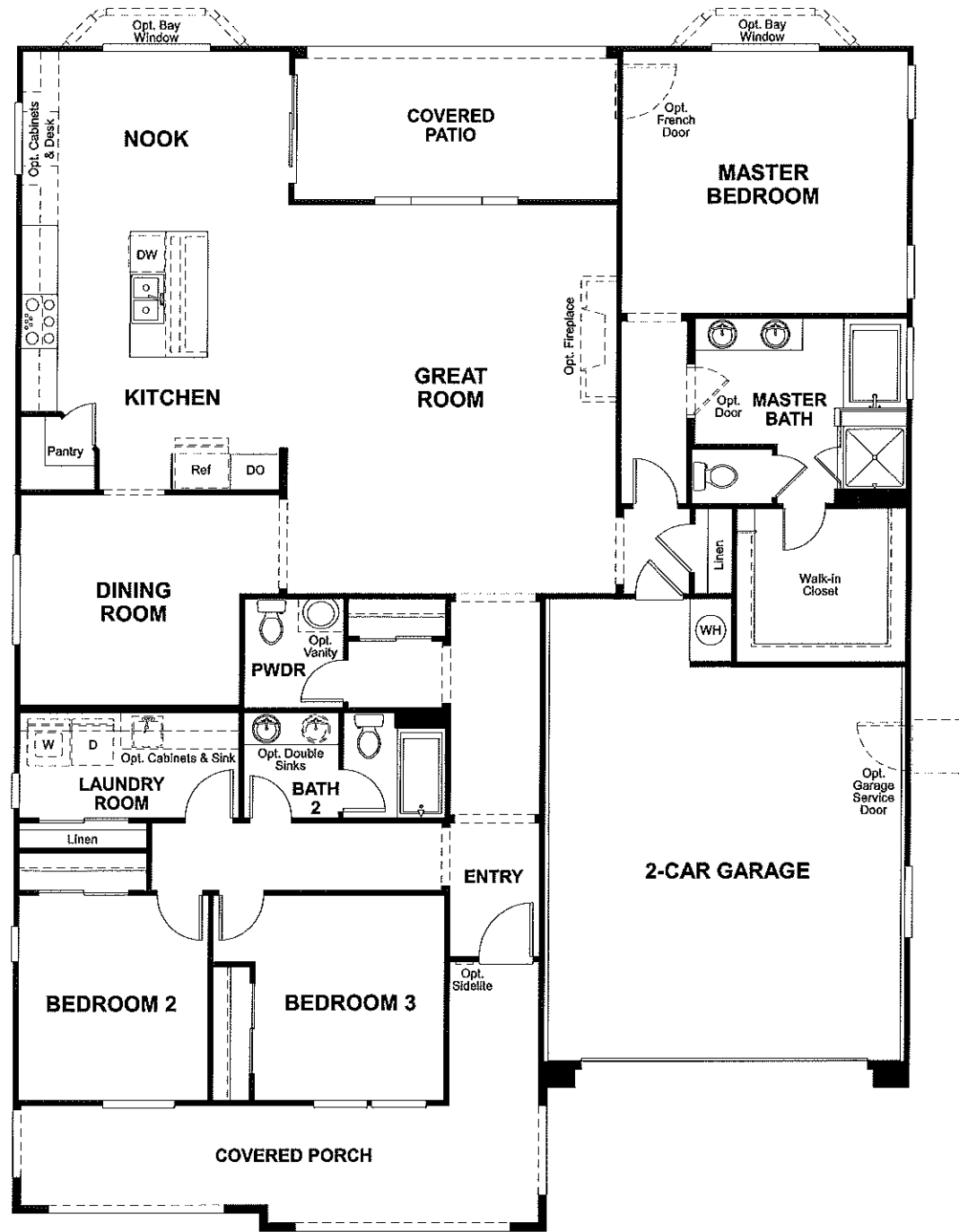

Floor Plan
Main Floor Options

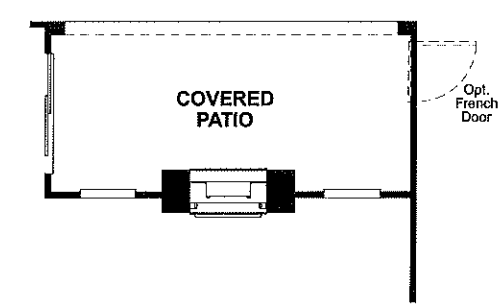

OPT. 2-SIDED FIREPLACE

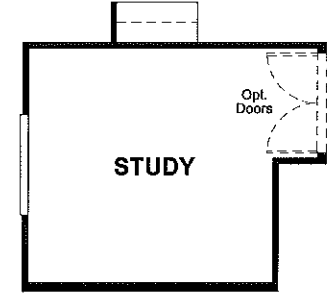

OPT. STUDY

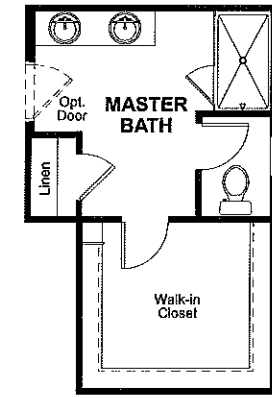

OPT. MASTER SHOWER

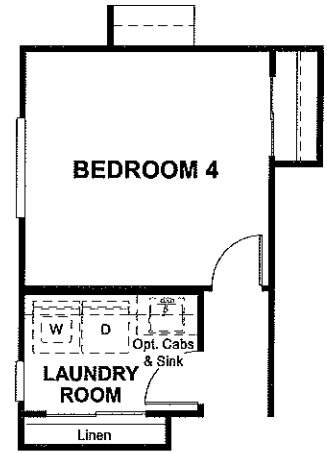

OPT. BEDROOM 4

THIS PLAN'S PROJECTED HERS® INDEX = 57*
Projected Rating Based on Plans – Field Confirmation Required

How does this floor plan rate?
Take a look: **100** = Standard new home* **130** = Typical resale home**
The lower the number, the better! Refer to the RESNET® HERS index brochure or go to www.RESNET.us for details.

What's a HERS® Index? HERS stands for Home Energy Rating System, a system created by RESNET® to measure home energy efficiency. A Projected HERS index or rating is a computer simulation performed prior to construction by a third-party HERS rater using RESNET-accredited rating software, rated feature and specification data derived from home plans, features and specifications, and other data selected or assumed by the rater. The projected HERS index is approximate and is subject to change without notice. Actual results will vary.

*This information is presented for education purposes only. The HERS index for a confirmed rating will be determined by a third-party HERS rater based on data gathered from on-site observations and, if required, testing of rated features for a home as featured, optioned, located, oriented and/or built.
+Standard new home is based on the RESNET® Reference Home definition with a HERS® index of 100 (based on the 2006 International Energy Conservation Code).
**Typical resale home is based on the U.S. Department of Energy definition with a HERS® index of 130.

*RESNET® has developed the HERS® index to indicate the comparative efficiencies of homes. It is no guarantee that energy efficiencies will be achieved.

Crescendo at Cadence
DELANEY



Elevation A

Approx. square feet: 2,200
Stories: 1
Bedrooms: 3 - 4
Garage: 2-car
Plan Number: L22D

The foyer of this Delaney floor plan leads to a generous great room and kitchen with walk-in pantry and central island. Also enjoy the master bedroom—tucked away for added privacy. A covered patio in the backyard completes this beautiful home.

Available elevations:



Elevation A



Elevation B



Elevation C

COMMUNITY LOCATION

Lake Mead Drive and Warm Springs Road
Henderson, NV 89015
702-638-4440

HOME GALLERY

7770 South Dean Martin Drive, Suite 308
Las Vegas, NV 89139
702-617-8400



COMMUNITY LOCATION

Lake Mead Drive and Warm Springs Road
Henderson, NV 89015
702-638-4440

HOME GALLERY

7770 South Dean Martin Drive, Suite 308
Las Vegas, NV 89139
702-617-8400

